

**PLAN VIEW  
HEAD FRAME - 4**

90mm x 45mm  
C-CHANNEL

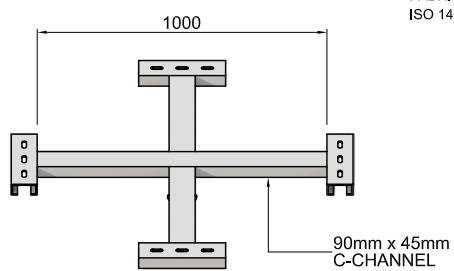

**HEAD FRAME - 4**

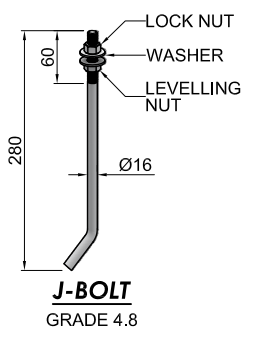

**J-BOLT  
GRADE 4.8**

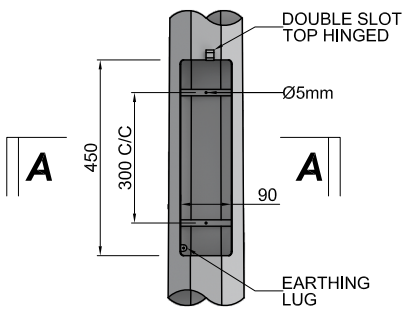

**SERVICE DOOR  
DETAIL**

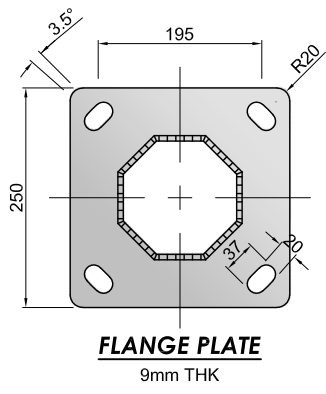

**FLANGE PLATE  
9mm THK**

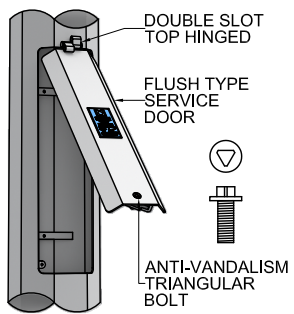

**SERVICE DOOR  
DIAGONAL VIEW**

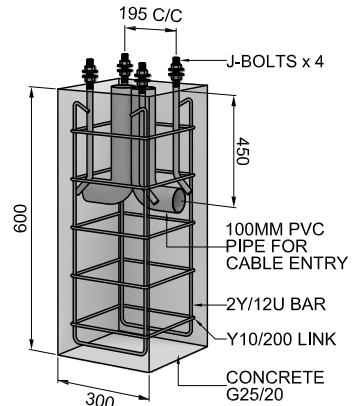

**FOOTING DETAIL**

MESTRON 4000 NOMINAL HEIGHT

HOT-DIP GALVANIZING - ISO 1461 : 2009  
2.5mm MILD STEEL PLATE - BS EN 10025 S275 JR (G) : 2004

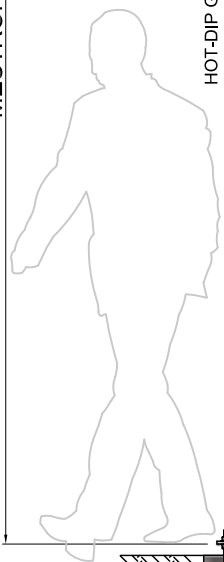

FLUSH TYPE  
SERVICE DOOR  
450mm x 90mm

A/F - 121  
GROUND LEVEL

305

WEIGHT (KGS) : 28 KGS

**MESTRON ENGINEERING**  
SDN BHD (591970-X)

TEL : +603 . 8069 1815  
FAX : +603 . 8069 1805  
EMAIL : info@mestron.com.my  
WEB : www.mestron.com.my

4M OCTAGONAL LIGHTING POLE FLANGE MOUNTED TYPE  
HEAD FRAME - 4 (CROSS)

DRAWN BY : HAFIZ  
CHECKED BY : NEO  
DRAWING NO. : 4M-FM-HF4(C)

THIS DRAWING IS THE PROPERTY OF  
MESTRON ENGINEERING SDN. BHD. AND MUST  
NOT BE REPRODUCED OR MISUSED WITHOUT  
THEIR PRIOR CONSENT IN WRITING.

ISSUE OF DATE : 01-01-2024