

# CURVED ARM

With a wider road in mind, Street Lighting Pole with curve arm is specially designed for a better coverage due to its extended reach. It is optimized for main road and expressway.

## OPTION AND ACCESSORIES

- 6M to 15M height
- Curve arm from 1.5M to 3.0M
- Spigot arm Dia. 48/60mm
- Fiberglass Service Door
- Anti-Stick Paint
- Twin Flag Holder
- Retractable Banner Holder

## STANDARD LIGHTING POLE

by Mestron®

## TECHNICAL SPECIFICATION

**1** LIGHTING POLE COMPLY TO **BS EN 40-5 : 2002** "LIGHTING COLUMNS, REQUIREMENT FOR STEEL LIGHTING COLUMNS"

**2** DESIGN OF POLE ARE COMPREHENSIVELY ANALYSED USING STAAD. PRO V8i STRUCTURAL DESIGN SOFTWARE TO WITHSTAND **35 M/S** WIND-SPEED, TERRAIN ROUGHNESS AND STATISTICAL FACTOR OF **1.0**

**3** POLE DESIGN VALIDATED WITH TYPE TEST "DESIGN AND VERIFICATION", TESTING IN ACCORDANCE TO **BS EN 40-3-2 : 2013**

**4** MATERIAL USED FOR LIGHTING POLE COMPLY TO **BS EN 10025 S275 JR : 2004 / JIS G3101 : 2010 / SS400** WITH MINIMUM YIELD AND TENSILE STRENGTH OF **275 MPa** AND **430 MPa** RESPECTIVELY

**5** WELDING PROCESS OF LIGHTING POLE IN COMPLIANCE TO WELDING PROCESS SPECIFICATION AS PER **BS EN 1011-2 : 2001**

**6** PRODUCTS ARE TREATED WITH ANTI-CORROSIVE TREATMENT KNOWN AS HOT-DIP GALVANIZED COATINGS ON FABRICATED IRON AND STEEL ARTICLES IN ACCORDANCE TO **BS EN ISO 1461 : 2009**

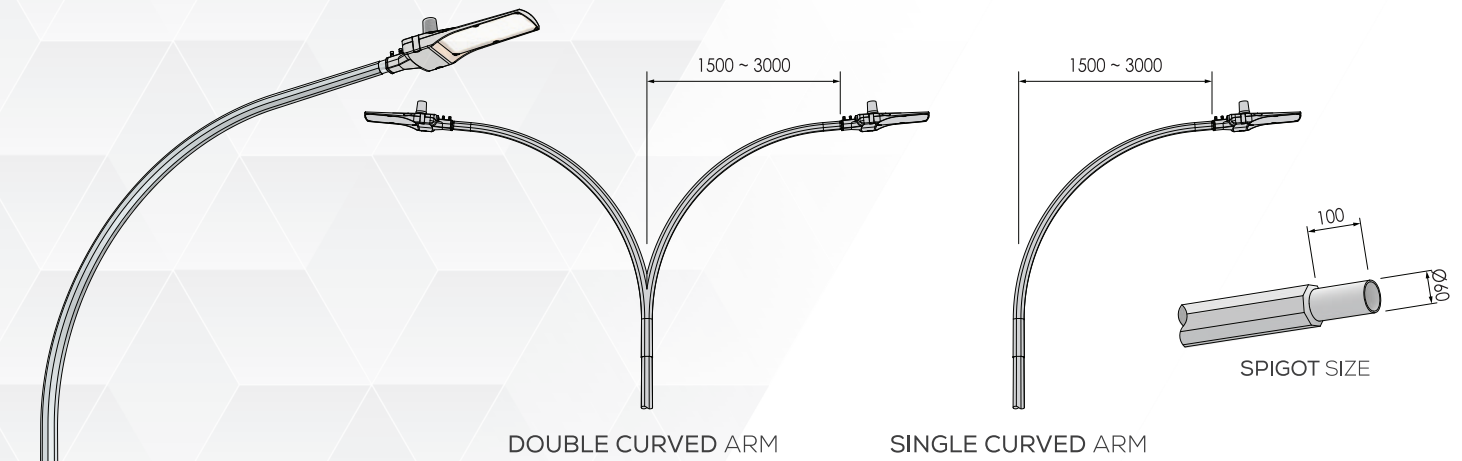

FLANGE MOUNTED TYPE

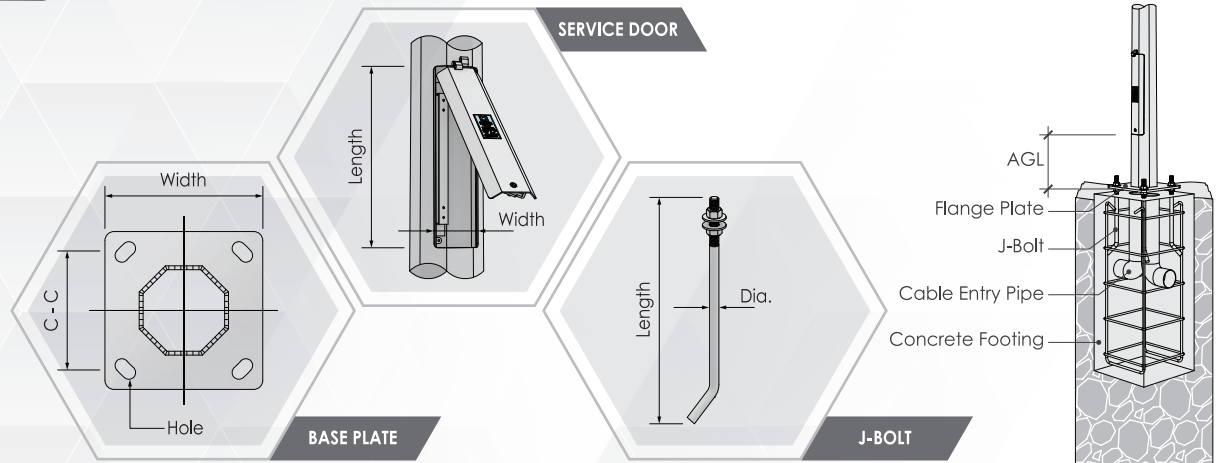

Pole(M)	SECTION HEIGHT			BASE FLANGE PLATE				SERVICE DOOR			J-BOLT		CONCRETE FOOTING		
	Bottom	Int.	Top	Width	C - C	Hole	THK	AGL	Width	Length	Dia.	Length	Width	Height	C - C
6	4350	-	1800	300	220	45 x 26	12	305	100	450	20	450	350	900	220
8	6350	-	1800	300	220	45 x 26	12	305	110	450	20	450	400	1000	220
9	2050	5600	1800	300	220	45 x 26	15	610	120	450	20	450	400	1000	220
10	3050	5600	1800	350	260	52 x 30	16	610	120	450	24	570	450	1100	260
12	5050	5600	1800	400	300	56 x 30	18	610	120	450	24	570	500	1200	300

\*All Dimension are in Millimeter (MM) unless stated

PLANTED TYPE

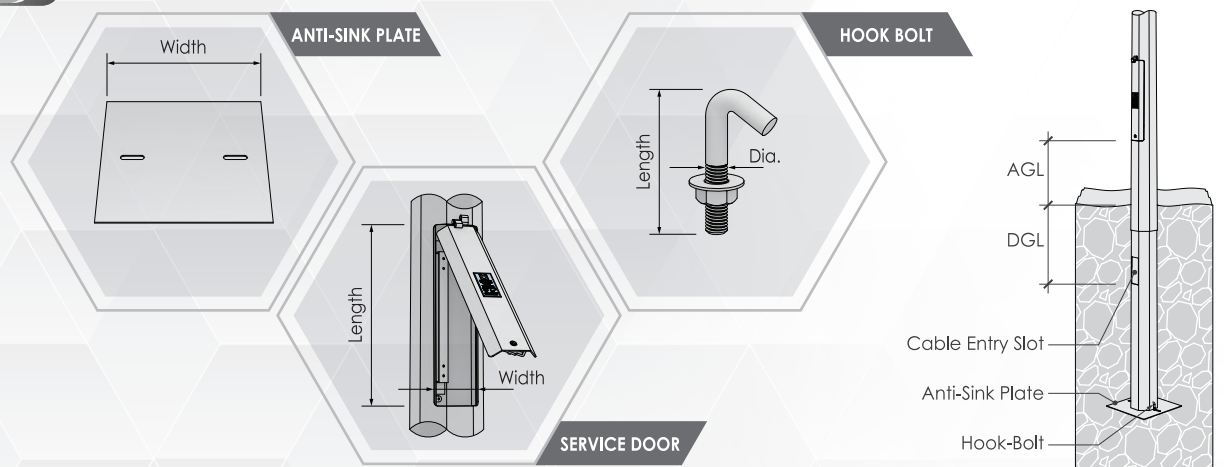

Pole(M)	SECTION HEIGHT			ANTI-SINK PLATE			SERVICE DOOR			HOOK-BOLT		PLANTING DEPTH		
	Bottom	Int.	Top	Width	THK	AGL	Width	Lenght	Dia.	Lenght	Depth	DGL	Cable Entry	
6	5600	-	1800	250	2.5	305	100	450	8	55	1200	500	150 x 60	
8	2450	5600	1800	300	2.5	305	110	450	8	55	1300	500	150 x 60	
9	3450	5600	1800	300	2.5	610	120	450	8	55	1400	500	150 x 60	
10	4550	5600	1800	300	2.5	610	120	450	8	55	1500	500	150 x 60	
12	6750	5600	1800	350	2.5	610	120	450	8	55	1700	500	150 x 60	

\*All Dimension are in Millimeter (MM) unless stated